

MAXIMUS MPXT SERIES2

NEW GENERATION OF EXPLOSION-PROOF DUAL VISION NETWORK PTZS WITH RADIOMETRIC FUNCTIONS



- PTZ network camera with dual sensor, thermal and Full HD
- Certified explosion-proof for use in Zones 1 and 2, Group IIC (Gas), Zones 21 and 22, Group IIIC (Dust)
- Certified up to a temperature of +80°C
- Maximum resistance in corrosive environments
- Junction box with integrated SFP slot to allow fiber optic connection



MAXIMUM RESISTANCE IN THE MOST CRITICAL ENVIRONMENTS

MAXIMUS MPXT SERIES2 is the new generation ex-proof PTZ Dual Vision with Day/Night camera and LWIR thermal camera with radiometric functions.

This certified ex-proof PTZ camera is the optimum solution for effective video surveillance and process control in the Oil & Gas, Maritime and Industrial sectors and in environments where there is a risk of fire or explosion as a result of flammable gases or vapours, flammable liquids or combustible dust being present.

MAXIMUS MPXT SERIES2 offers maximum resistance in corrosive environments with industrial and marine environments thanks to construction in AISI 316L stainless steel and micro-shot peened and electro-polished surfaces. Furthermore, the IP66/IP67/IP68/IP69, NEMA Type 4X and Type 6P certification guarantees complete protection against water and dust entry, even in difficult conditions.

CERTIFIED QUALITY

Every version of MAXIMUS MPXT SERIES2 PTZ is explosion-proof certified with a ambient temperature of up to +80°C. They have international certifications for use in Zone 1 and 2, Group IIC for gas, Zone 21 and 22, Group IIIC, Class 1 Div. 2, for dust (ATEX, IECEx, UL/CSA, EAC Ex, INMETRO, KCs). Thanks to the double cable entry, both 120Vac and 230Vac voltage supply versions are compliant with UL/CSA standards.

MAXIMUS MPXT SERIES2 products are Lloyd's Register Marine Type Approval System Test Specification Number 1 certified and can be used in Marine and Offshore.

INSTALLATION FLEXIBILITY

The SERIES2 range of cameras can easily connect the PTZ via fibre optic thanks to the SFP module slot installed directly into the junction box integrated into the base of the unit.

The double cable entry and the numerous accessories and supports available (washing system, communication box, pre-wired cables, cable glands, wall supports, railing supports, corners and pole), allow exceptional installation flexibility.

SONY FCB-EV7520 CAMERA

The visible camera is a SONY FCB-EV7520 with 30x optical zoom and a 1/2.8" Exmor R™ CMOS sensor with Full HD 1080/60p resolution that produces the highest image quality, even when filming moving objects or in poor lighting conditions. The advanced SONY technology brings Wide Dynamic Range and a configurable High Light Compensation that allows optimal management of areas subject to vibrations and contrasting light and dark conditions. You can set up to 24 dynamic privacy zone masks.

RADIOMETRIC FUNCTIONS FOR MEASURING TEMPERATURE

The integrated thermal camera can identify targets moving in the dark or at distance with extreme accuracy. As well as this, it has radiometric functions that allow precise temperature detection based on the image's 4 main pixels. The device can be configured so that it independently generates a Radiometric Alarm and/or Warning via ONVIF Events on the VMS. For example, an event can be sent when: the temperature is below a settable value; the temperature is above a settable value; the temperature is between two settable values; the temperature is outside two settable values. This function is particularly useful when monitoring industrial processes.

In camera models with advanced radiometric functions, up to 5 ROIs (Regions of Interest) can be set for each preset position. The defined ROIs are scaled proportionally to the digital zoom. So, when zooming in the ROI is increased and when zooming out the ROI is decreased. PTZ ROIs are set to preset PAN and TILT positions (not zoom) so they then change in relation to the zoom. In camera models with advanced radiometric functions, thermal cameras offer three temperatures: minimum, average and maximum. Radiometric rules can be linked to exceeding one of these three temperature thresholds.

GEOMOVE FUNCTION

The GeoMove function offered by the new MAXIMUS MPXT SERIES2 uses two connected cameras that communicate with each other through intelligent language, meaning advanced actions can be carried out in even the most basic surveillance systems.

GeoMove can be used with fixed or PTZ cameras that have VIDEOTEC ANALYTICS and monitor a certain area. When a target is sighted, the camera sends the geo-coordinates of the target to a MAXIMUS MPXT SERIES2 PTZ that uses them to frame the target.

The GeoMove function can interface with third-party software that gives an objects geo-coordinates, such as Video Management Software (VMS) for traditional video surveillance where a target needs to be shown on a map, or Vessel Tracking Service (VTS) for navigation control services (also combined with radar control systems).

100% MADE IN VIDEOTEC

SERIES2 offers an integrated certified all-in-one professional solution. Since everything from mechanics to electronics, positioning and networking, software and firmware are all proudly developed end-to-end by Videotec's internal teams, as is the case for all the company's products, these PTZs come with the Videotec guarantee of being reliable, cyber-safe, future-proof and easily integrated with third-party products.

At the heart of Videotec's product development is the concept of cyber-sustainability. To help customers protect their video surveillance systems and keep them secure, Videotec provides constant updates, training and support throughout the lifecycle of its products, regardless of how old the device is or whether it is still for sale.

Thanks to digitally signed firmware, password-restricted access, access control, centralised management of certificates and compliance with ONVIF Security Service specifications, Videotec guarantees that all its IP products will have the highest level of security during data transfer and device access.

In the SERIES2, Videotec has expanded the list of compatible software, but has not changed the tested and proven software functions and protocols already found in the MAXIMUS MPX series. As a result, Videotec can guarantee complete compatibility and interchangeability between the previous and new generations of PTZ, while protecting the investments made by its customers when it comes to validation and integration of MAXIMUS MPX.

TECHNICAL DATA

GENERAL

AISI 316L stainless steel construction

External surfaces micro-shot peened and electro-polished

Dynamic positioning control system

Maximum number of presets: 250

Radiometric analysis:

- on the 4 central pixels, if the thermal camera has radiometric functions
- definition of a specific area, if the thermal camera has advanced radiometric functions

Radiometric alarm activation: If the temperature is over the threshold set, under the threshold set, between two thresholds set or outside the two thresholds set.

Actions on alarm: Activation of digital output, preset tour recall, home position recall, preset position recall and http get request.

MECHANICAL

Cable inputs: 2 x 3/4" NPT

Zero backlash

Horizontal rotation: 360°, continuous rotation

Vertical rotation: from -90° up to +90°

Horizontal speed (variable): from 0.1°/s to 100°/s

Tilt speed (variable): from 0.1°/s to 100°/s

Accuracy of preset positions: 0.02°

Integrated wiper

Unit weight: 31kg (68lb)

HOUSING'S WINDOW

Window with extra clear tempered glass

- Thick: 12mm (0.47in)

Germanium window

- Thick: 8mm (0.3in)
- Scratch-resistant treatment (Hard Carbon Coating - DLC)
- Antireflection treatment
- Spectral range: from 7.5µm up to 14µm
- Medium transmittance (from 7.5µm up to 11.5µm): 87.5%
- Medium transmittance (from 11.5µm up to 14µm): 72.1%

ELECTRICAL

Supply voltage/Current consumption:

- 230Vac ±10%, 0.5A, 50/60Hz
- 24Vac ±10%, 5A, 50/60Hz
- 120Vac ±10%, 1A, 50/60Hz
- 220Vac ±10%, 0.54A, 50/60Hz
- 100Vac ±10%, 1.2A, 50/60Hz

Power consumption:

- 120W max

NETWORK

RJ45 port

- Ethernet connection: 10BASE-T/100BASE-T

Slot SFP (SMALL FORM FACTOR PLUGGABLE)

- Ethernet connection: 100BASE-FX
- Supply voltage: 3.3V
- Standard: MSA compliant

The SFP module (not supplied by VIDEOTECH) must meet the following requirements:

- Laser: Class 1, complies with EN60825-1
- Certification: UL/IEC 60950-1 or UL/IEC 62368-1

CYBERSECURITY

Digitally signed firmware

Password restricted access (HTTP digest)

Support of various user access levels

Control of accesses IEEE 802.1X

HTTPS cryptography using TLS1.0, TLS1.1, TLS1.2 and TLS1.3

Centralised certificate management

Complies with ONVIF Security Service specifications

I/O INTERFACE

Input for remote reset: 1

Alarm inputs: 1

Relay outputs: 1+1 (1A, 30Vac/60Vdc max, one relay reserved for washer pump and one configurable)

VIDEO

Day/Night camera

Video encoder

- Communication protocol: ONVIF, Profile Q, Profile S and Profile T
- Device configuration: TCP/IPv4-IPv6, UDP/IPv4-IPv6, HTTP, HTTPS, NTP, DHCP, WS-DISCOVERY, DSCP, IGMP (Multicast), SOAP, DNS
- Streaming: RTSP, RTCP, RTP/IPv4-IPv6, HTTP, Multicast
- Video compression: H.264/AVC, MJPEG, MPEG4, snapshot JPEG
- 3 independent video streams Full HD
- Image resolution: from 320x180pixel up to 1920x1080pixel in 8 steps
- Selectable frame rate from 1 to 60 images per second (fps)
- Web Server
- Directional OSD (maximum 4 settable areas)
- Motion Detection
- QoS: Differentiated DSCPs for streaming and device management
- SNMP and NTCIP protocols

Thermal Camera

Video encoder

- Communication protocol: ONVIF, Profile Q, Profile S and Profile T, ONVIF Thermal Service
- Device configuration: TCP/IPv4-IPv6, UDP/IPv4-IPv6, HTTP, HTTPS, NTP, DHCP, WSDISCOVERY, DSCP, IGMP (Multicast), SOAP, DNS
- Streaming: RTSP, RTCP, RTP/IPv4-IPv6, HTTP, Multicast
- Video compression: H.264/AVC, MJPEG, MPEG4, snapshot JPEG
- 3 independent video streams
- Image resolution: from 160x120pixel up to 720x480pixel in 5 steps
- Selectable frame rate from 1 to 30 images per second (fps)
- Web Server
- Directional OSD (maximum 4 settable areas)
- Motion Detection
- QoS: Differentiated DSCPs for streaming and device management
- SNMP and NTCIP protocols

DAY/NIGHT CAMERA

SONY FCB-EV7520 Day/Night Full HD 30x

Resolution: Full HD 1080p (1920x1080)

Image Sensor: 1/2.8" Exmor™ R CMOS sensor

Effective Pixels: approx. 2.13 Megapixels

Minimum Illumination:

- Colour: 0.0013lx (50 IRE, High sensitivity on)
- B/W: 0.0008lx (30 IRE, High sensitivity on)

Focal length: from 4.3mm (wide) up to 129mm (tele)

Zoom: 30x (360x with digital zoom)

Iris: from F1.6 up to F14 (Auto, Manual)

Horizontal Viewing Angle: from 63.7° (wide end) up to 2.3° (tele end)

Vertical Viewing Angle: from 38.5° (wide end) up to 1.3° (tele end)

Shutter speed: from 1/1s up to 1/10000s (Auto, Manual)

White balance: Auto, Auto Tracing, Indoor, Outdoor, Manual, Outdoor Auto, Sodium Lamp (Fix/Auto/Outdoor Auto)

Gain: from 0dB up to 50.0dB (Auto, Manual)

Wide Dynamic Range: 120dB

Focus System: Auto (PTZ Trigger, Full Auto), Manual

Picture Effects: E-flip

Noise removal (2D, 3D): Off, On (from level 1 up to level 5)

Exposure Control: Auto, Manual, Priority (Shutter priority, Iris priority, Brightness priority)

De-fog: Off, Low, Mid, High

Dynamic masking of privacy zones: maximum 24 masks settable, maximum 8 simultaneously displayable

Indoor Flicker Reduction

Gain Limit: from 10.7dB up to 50dB

High sensitivity: On/Off

Backlight Compensation: On/Off

Auto Slowshutter: On/Off

Exposure compensation: Off, On (from -10.5dB up to +10.5dB)

Sharpness: from level 0 up to level 15

High Light Compensation (HLC): Off, Low, Mid, High, Masking Level (Off, On, from level 1 up to level 15)

Digital image stabilization: On/Off

THERMAL CAMERAS

Please refer to the relevant table.

ENVIRONMENT

For indoors and outdoors installation

Certification temperature: from -40°C (-40°F) up to +80°C (+176°F)

Temperature test complies with NEMA-TS 2-2003 (R2008) par. 2.1.5.1, test profile fig. 2-1 (from -34°C (-29.2°F) to +74°C (165.2°F))

De-icing function intervention (cold start): from -40°C (-40°F) up to -10°C (14°F)

Wind resistance

- PTZ static: 230km/h (143mph) max.
- PTZ operational at the maximum speed: 210km/h (130.5mph) max.

Relative humidity: from 5% up to 95%

CERTIFICATIONS

Electrical safety (CE): EN60950-1, IEC60950-1, EN62368-1, IEC62368-1

Electromagnetic compatibility (CE): EN50130-4, EN55032 (Class A), EN61000-6-4, EN61000-3-2, EN61000-3-3

RoHS (CE): EN50581

Outdoor installation (CE): EN60950-22, IEC60950-22

Vibration test: EN50130-5, EN60068-2-6

UL certification¹ (UL60950-1, CAN/CSA C22.2 No. 60950-1-07, UL62368-1, CAN/CSA C22.2 No. 62368-1-14): cULus Listed

Electromagnetic compatibility (North America): FCC part 15 (Class A), ICES-003 (Class A)

IP protection degree (EN/IEC60529): IP66, IP67, IP68, IP69

Level of protection Type (UL50E): 4X, 6P

RCM (Australian and New Zealand Regulatory Compliance Mark)

NDAA-compliant

CERTIFICATIONS - EXPLOSION-PROOF APPLICATIONS

ATEX (EN IEC 60079-0, EN 60079-1, EN 60079-31)

IECEX (IEC 60079-0, IEC 60079-1, IEC 60079-31)

UL listed for USA (UL 60079-0, UL 60079-1, UL 60079-31) (not available for 100Vac and 220Vac versions)

UL listed for Canada (CAN/CSA-C22.2 NO. 60079-0, CAN/CSA-C22.2 NO. 60079-1, CAN/CSA-C22.2 NO. 60079-31) (not available for 100Vac and 220Vac versions)

EAC Ex (TR CU 012/2011) (not available for 100Vac and 220Vac versions)

INMETRO (ABNT NBR IEC 60079-0, ABNT NBR IEC 60079-1, ABNT NBR IEC 60079-31) (not available for 100Vac and 220Vac versions)

KCs (Employment and labor department 2020-33)

For further details on certifications and markings, consult the relevant table.

CERTIFICATIONS - MARINE APPLICATIONS

Lloyd's Register Marine Type Approval certification (with MAXIMUS MBX communication box or with FM1010 filter):

Test Specification Number 1 (ENV1, ENV2, ENV3, ENV5)

Electromagnetic compatibility: EN60945

Salty fog resistance: EN60068-2-52

ACCESSORIES	
WASEX2T4AT	Tank 10l (2.6gal) with integrated manual pump controlled by ATEX certified solenoid valve, delivery head up to 20m (66ft) max, IN 24Vac/Vdc
WASEX2T4GOR	Tank 10l (2.6gal) with integrated manual pump controlled by EAC EX certified solenoid valve, delivery head up to 20m (66ft) max, IN 24Vac/Vdc
WASEX2T4IN	Tank 10l (2.6gal) with integrated manual pump controlled by INMETRO certified solenoid valve, delivery head up to 20m (66ft) max, IN 24Vac/Vdc
MBX1MAA	Explosion-proof communication box in stainless steel, IN 230Vac, with EMC filter for marine certification
MBX2MAA	Explosion-proof communication box in stainless steel, IN 24Vac, with EMC filter for marine certification
MBX3MAA	Explosion-proof communication box in stainless steel, IN 120Vac, with EMC filter for marine certification
MBA1SSA	Explosion-proof communication box in aluminium, IN 230Vac
MBA2SSA	Explosion-proof communication box in aluminium, IN 24Vac
MBA3SSA	Explosion-proof communication box in aluminium, IN 120Vac
OCTEX3/4C	Cable gland in nickel-plated brass with gasket EX 3/4" NPT, unarmoured cable IECEX-ATEX-EAC Ex
OCTEXA3/4C	Cable gland in nickel-plated brass with gasket EX 3/4" NPT, armoured cable IECEX-ATEX-EAC Ex
OCTEXB3/4P	Barrier cable gland in nickel-plated brass EX 3/4" NPT, unarmoured cable IECEX-ATEX-EAC Ex
OCTEXBA3/4P	Barrier cable gland in nickel-plated brass EX 3/4" NPT, armoured cable IECEX-ATEX-EAC Ex
OCTEX3/4	Cable gland in nickel-plated brass with gasket EX 3/4" NPT, unarmoured cable ATEX
OCTEXA3/4	Cable gland in nickel-plated brass with gasket EX 3/4" NPT, armoured cable ATEX
OCTEX1/2-3/4P	Cable glands reduction in nickel-plated brass Ex 3/4" - 1/2" NPT IECEX-ATEX-EAC Ex
OCTEXP3/4C	Conduit cable gland nickel-plated brass 3/4" NPT IECEX-ATEX- c CSA us - EAC Ex (operating temperature: from -60°C (-76°F) up to +80°C (+176°F))
OEXPLUG1/2P	Plug EX 1/2" NPT IECEX-ATEX-EAC Ex
OEXPLUG3/4P	Plug EX 3/4" NPT IECEX-ATEX-EAC Ex
FM1010	EMC filter for Marine certification
MPX2CABLARM4	Cabling for MAXIMUS MPX SERIES2, 4m (13.1ft), armoured cable, barrier cable gland: 1 Ethernet cable, 3 power supply conductors, 7 conductors for alarms and relay
MPX2CABL4	Cabling for MAXIMUS MPX SERIES2, 4m (13.1ft), unarmoured cable, barrier cable gland: 1 Ethernet cable, 3 power supply conductors, 10 conductors for alarms and relay
MPX2CABLARM10	Cabling for MAXIMUS MPX SERIES2, 10m (32.8ft), armoured cable, barrier cable gland: 1 Ethernet cable, 3 power supply conductors, 7 conductors for alarms and relay
MPX2CABL10	Cabling for MAXIMUS MPX SERIES2, 10m (32.8ft), unarmoured cable, barrier cable gland: 1 Ethernet cable, 3 power supply conductors, 10 conductors for alarms and relay

For further details about cable glands part numbers, please refer to the relevant table.

BRACKETS AND ADAPTORS	
MPXCW	AISI 316L stainless steel corner adapter module
MPXWBA	AISI 316L stainless steel wall bracket
MPXCOL	AISI 316L stainless steel pole adapter module
MPXWBTA	AISI 316L stainless steel parapet or ceiling mounting bracket

PACKAGE			
Model Number	Weight	Dimensions (WxHxL)	Master carton
MPXT12AA000C	35kg (77lb)	54x31x49cm (21x12x19in)	-

THERMAL CAMERAS (RESOLUTION 336X256)					
	Lens 9mm	Lens 13mm	Lens 19mm	Lens 25mm	Lens 35mm
Image Sensor	Uncooled VOx microbolometer	Uncooled VOx microbolometer	Uncooled VOx microbolometer	Uncooled VOx microbolometer	Uncooled VOx microbolometer
Interpolated resolution	720x480	720x480	720x480	720x480	720x480
Pixel dimensions	17µm	17µm	17µm	17µm	17µm
Spectral response - long wave infrared (LWIR)	from 7.5µm to 13.5µm	from 7.5µm to 13.5µm	from 7.5µm to 13.5µm	from 7.5µm to 13.5µm	from 7.5µm to 13.5µm
Internal shutter (only for sensor compensation)	Video stop < 1s	Video stop < 1s	Video stop < 1s	Video stop < 1s	Video stop < 1s
Digital Detail Enhancement (DDE)	✓	✓	✓	✓	✓
Digital Zoom	2x, 4x	2x, 4x	2x, 4x	2x, 4x	2x, 4x
Image updating frequency	7.5fps	7.5fps	7.5fps	7.5fps	7.5fps
Image updating high frequency	30fps	30fps	30fps	30fps	30fps
Scene range (High Gain)	-40°C ÷ +160°C (-40°F ÷ +320°F)	-40°C ÷ +160°C (-40°F ÷ +320°F)	-40°C ÷ +160°C (-40°F ÷ +320°F)	-40°C ÷ +160°C (-40°F ÷ +320°F)	-40°C ÷ +160°C (-40°F ÷ +320°F)
Scene range (Low Gain)	-40°C ÷ +550°C (-40°F ÷ +1022°F)	-40°C ÷ +550°C (-40°F ÷ +1022°F)	-40°C ÷ +550°C (-40°F ÷ +1022°F)	-40°C ÷ +550°C (-40°F ÷ +1022°F)	-40°C ÷ +550°C (-40°F ÷ +1022°F)
Horizontal field of view (HFOV)	35°	25°	17°	13°	9.3°
Vertical field of view (VFOV)	27°	19°	13°	10°	7.1°
F-number	F/1.25	F/1.25	F/1.25	F/1.1	F/1.2
Thermal sensitivity (NETD), Thermal camera with radiometric functions	< 50mK at f/1.0	< 50mK at f/1.0	< 50mK at f/1.0	< 50mK at f/1.0	< 50mK at f/1.0
Thermal sensitivity (NETD), Thermal camera with advanced radiometric functions	< 30mK at f/1.0	< 30mK at f/1.0	< 30mK at f/1.0	< 30mK at f/1.0	< 30mK at f/1.0
Person (detection / recognition / identification)	285m / 71m / 36m (935ft / 233ft / 118ft)	440m / 112m / 56m (1443ft / 236ft / 183ft)	640m / 160m / 80m (2099ft / 524ft / 262ft)	930m / 230m / 116m (3051ft / 754ft / 380ft)	1280m / 320m / 160m (4199ft / 1050ft / 525ft)
Car (detection / recognition / identification)	880m / 220m / 108m (2887ft / 722ft / 354ft)	1340m / 340m / 170m (4396ft / 1115ft / 557ft)	1950m / 500m / 250m (6397ft / 1640ft / 820ft)	2800m / 710m / 360m (9186ft / 2329ft / 1181ft)	3850m / 950m / 295m (12631ft / 3116ft / 967ft)

Radiometric analysis does not affect camera performance.

THERMAL CAMERAS (RESOLUTION 640X512)			
	Lens 19mm	Lens 25mm	Lens 35mm
Image Sensor	Uncooled VOx microbolometer	Uncooled VOx microbolometer	Uncooled VOx microbolometer
Interpolated resolution	720x480	720x480	720x480
Pixel dimensions	17µm	17µm	17µm
Spectral response - long wave infrared (LWIR)	from 7.5µm to 13.5µm	from 7.5µm to 13.5µm	from 7.5µm to 13.5µm
Internal shutter (only for sensor compensation)	Video stop < 1s	Video stop < 1s	Video stop < 1s
Digital Detail Enhancement (DDE)	✓	✓	✓
Digital Zoom	2x, 4x, 8x	2x, 4x, 8x	2x, 4x, 8x
Image updating frequency	7.5fps	7.5fps	7.5fps
Image updating high frequency	30fps	30fps	30fps
Scene range (High Gain)	-40°C ÷ +160°C (-40°F ÷ +320°F)	-40°C ÷ +160°C (-40°F ÷ +320°F)	-40°C ÷ +160°C (-40°F ÷ +320°F)
Scene range (Low Gain)	-40°C ÷ +550°C (-40°F ÷ +1022°F)	-40°C ÷ +550°C (-40°F ÷ +1022°F)	-40°C ÷ +550°C (-40°F ÷ +1022°F)
Horizontal field of view (HFOV)	32°	25°	18°
Vertical field of view (VFOV)	26°	20°	14°
F-number	F/1.25	F/1.1	F/1.2
Thermal sensitivity (NETD), Thermal camera with radiometric functions	< 50mK at f/1.0	< 50mK at f/1.0	< 50mK at f/1.0
Thermal sensitivity (NETD), Thermal camera with advanced radiometric functions	< 30mK at f/1.0	< 30mK at f/1.0	< 30mK at f/1.0
Person (detection / recognition / identification)	570m / 144m / 72m (1870 / 472 / 236ft)	820m / 210m / 104m (2690ft / 689ft / 341ft)	1140m / 280m / 142m (3740ft / 919ft / 466ft)
Car (detection / recognition / identification)	1550m / 400m / 200m (5085ft / 1312ft / 656ft)	2200m / 580m / 290m (7218ft / 1903ft / 951ft)	3000m / 800m / 200m (9843ft / 2625ft / 656ft)

Radiometric analysis does not affect camera performance.

CABLE GLANDS AND ACCESSORIES 3/4" NPT

Type	Certification	Operating temperature	Cable	Model Number	Diameter of the external cable	Under armor cable diameter
Barrier cable gland	IECEX/ATEX/EAC Ex	-60°C (-76°F) / +135°C (+275°F)	Unarmoured cable	OCTEXB3/4P	17.8 - 20.0mm (0.70-0.79in)	–
			Armoured cable	OCTEXBA3/4P	16.8 - 23.9mm (0.66-0.94in)	20mm (0.79in) max
Cable gland with gasket	IECEX/ATEX/EAC Ex	-60°C (-76°F) / +100°C (+212°F)	Unarmoured cable	OCTEX3/4C	13.0 - 20.2mm (0.51-0.79in)	–
			Armoured cable	OCTEXA3/4C	16.9 - 26.0mm (0.66-1.02in)	11.1 - 19.7mm (0.44 - 0.78in)
	ATEX	-40°C (-40°F) / +100°C (+212°F)	Unarmoured cable	OCTEX3/4	14.0 - 17.0mm (0.55-0.67in)	–
			Armoured cable	OCTEXA3/4	18.0 - 23.0mm (0.71-0.91in)	14 - 17mm (0.55 - 0.67in)
Plug EX 3/4"NPT	IECEX/ATEX/EAC Ex	-100°C (-148°F) / +400°C (+752°F)	–	OEXPLUG3/4P	–	–
Conduit sealing fitting	IECEX-ATEX- c CSA us - EAC Ex	-60°C (-76°F) / +80°C (+176°F)	–	OCTEXP3/4C	–	–
Reduction 3/4" NPT x 1/2" NPT	IECEX/ATEX/EAC Ex	-100°C (-148°F) / +400°C (+752°F)	–	OCTEX1/2-3/4P	–	–

MAXIMUS MPXT SERIES2 - CERTIFICATIONS AND MARKINGS

Part number	Certification	Marking	Ambient temperature	Cable entry temperature
MPXT1*AO**C MPXT2*AO**C, MPXT3*AO**C	ATEX	⊕ II 2 G Ex db IIC T6...T5 Gb ⊕ II 2D Ex tb IIIC T85°C...T100°C Db	-40°C ≤ Ta ≤ +60°C or +70°C	80°C
	IECEX	Ex db IIC T6...T5 Gb Ex tb IIIC T85°C...T100°C Db		
	EAC Ex	1Ex d IIC T6...T5 Gb X Ex tb IIIC T85°C...T100°C Db X		
	INMETRO	Ex db IIC T6...T5 Gb Ex tb IIIC T85°C...T100°C Db		
	KCs	Ex d IIC T6...T5 Ex tb IIIC T85°C...T100°C		
	UL Hazardous Location America	Class I, Zone 1, AEx db IIC T6...T5 Gb Zone 21, AEx tb IIIC T85°C...T100°C Db Class I, Div 2, Group A, B, C, D T6...T5 Class II, Div 2, Group F, G T6...T5		
	UL Hazardous Location Canada	Ex db IIC T6...T5 Gb X Ex tb IIIC T85°C...T100°C Db X Class I, Div 2, Group A, B, C, D T6...T5 Class II, Div 2, Group F, G T6...T5		
MPXT5*AO**C MPXT6*AO**C	ATEX	⊕ II 2 G Ex db IIC T6...T5 Gb ⊕ II 2D Ex tb IIIC T85°C...T100°C Db	-40°C ≤ Ta ≤ +80°C	80°C
	IECEX	Ex db IIC T6...T5 Gb Ex tb IIIC T85°C...T100°C Db		
	KCs	Ex d IIC T6...T5 Ex tb IIIC T85°C...T100°C		
MPXT1*D0**C MPXT2*D0**C, MPXT3*D0**C	ATEX	⊕ II 2G Ex db IIC T4 Gb ⊕ II 2D Ex tb IIIC T135°C Db	-40°C ≤ Ta ≤ +80°C	90°C
	IECEX	Ex db IIC T4 Gb Ex tb IIIC T135°C Db		
	EAC Ex	1Ex d IIC T4 Gb X Ex tb IIIC T135°C Db X		
	INMETRO	Ex db IIC T4 Gb Ex tb IIIC T135°C Db		
	KCs	Ex d IIC T4 Ex tb IIIC T135°C		
MPXT5*D0**C MPXT6*D0**C	ATEX	⊕ II 2G Ex db IIC T4 Gb ⊕ II 2D Ex tb IIIC T135°C Db	-40°C ≤ Ta ≤ +80°C	90°C
	IECEX	Ex db IIC T4 Gb Ex tb IIIC T135°C Db		
	KCs	Ex d IIC T4 Ex tb IIIC T135°C		

MAXIMUS MPXT SERIES2 - CONFIGURATION OPTIONS

	Voltage	Day/Night camera	Thermal Camera	Temperature class	Radiometry	ONVIF Profiles	Frequency
MPXT	1 230Vac	2 SONY FCB-EV7520 camera, FULL HD 1080p, 30x	A 9.3° HFOV, Thermal camera 35mm, 336x256	A T6...T5 -40°C/+60°C or +70°C	00 Thermal camera with radiometric functions	0 Complies with ONVIF, Profile Q, Profile S and Profile T	C - 7.5Hz
	2 24Vac		B 13° HFOV, Thermal camera 25mm, 336x256	D T4 -40°C/+80°C	0R Thermal camera with advanced radiometric functions	1 Complies with ONVIF, Profile S and Profile T	H 30Hz
	3 120Vac		V 17° HFOV, Thermal camera 19mm, 336x256				
	5 220Vac		F 25° HFOV, Thermal camera 13mm, 336x256				
	6 100Vac		C 35° HFOV, Thermal camera 9mm, 336x256				
			D 18° HFOV, Thermal camera 35mm, 640x512				
			E 25° HFOV, Thermal camera 25mm, 640x512				
			U 32° HFOV, Thermal camera 19mm, 640x512				

Not all combinations are possible.

TECHNICAL DRAWINGS

The indicated measurements are expressed in millimetres.

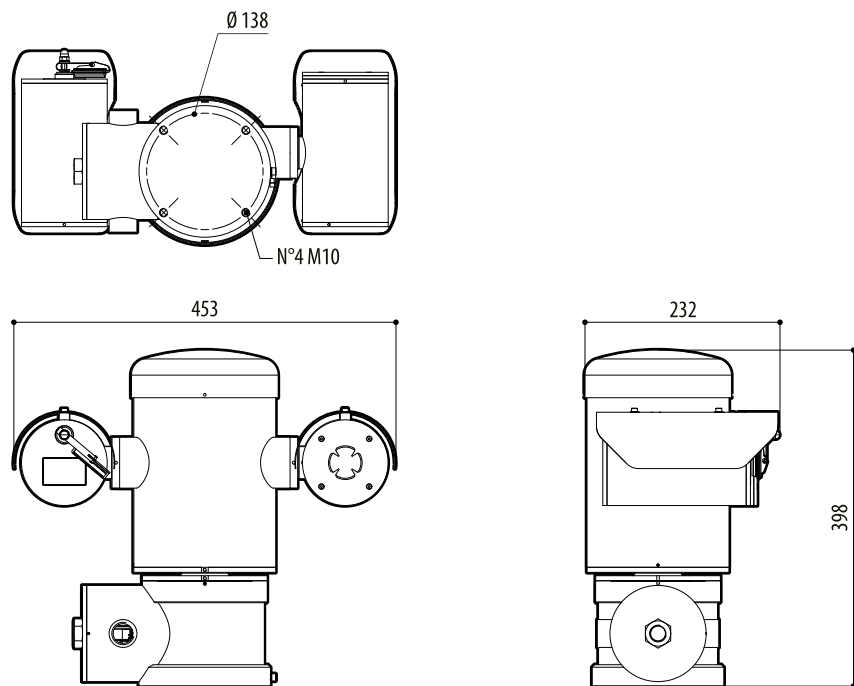

MAXIMUS MPXT SERIES2