

iDS-TCV900-BI 9 MP IR ANPR Checkpoint Capture Unit



- High quality imaging with 9 MP resolution (1"GMOS)
- Excellent low-light performance, color: 0.001 Lux @ (F1.4, AGC ON), 0.0005 Lux with IR
- Efficient H.265 compression technology
- 3D DNR technology delivers clean and sharp images
- Support license plate recognition (LPR)
- Vehicle feature recognition: vehicle type/color/manufacturer/license plate color recognition, no-plate vehicle capture
- Violation behaviors detection: driving on lane line, lane change, wrong-way driving detection, seatbelt and phone call detection.
- Application Scenarios: highway, tunnel, toll station, urban road, etc.

▪ Specification

Camera	
Image Sensor	9 MP (1" GMOS)
Max. Resolution	4096 × 2160
Min. Illumination	Color: 0.001 Lux @ (F1.4, AGC ON), 0.0005 Lux with IR
Shutter Time	50 us - 20000 us
Day & Night	IR cut filter
Lens	
Lens Type	Fixed focal lens, 25 mm, Varifocal lens, manual adjustment, 11 to 40 mm, (AF)Model: Varifocal lens, motorized lens, 11 to 40 mm
Focal Length & FOV	25 mm, horizontal FOV 32°, vertical FOV 16.8°, diagonal FOV 36.3°, 11 to 40 mm, horizontal FOV 62° to 23.6°, vertical FOV 32.2° to 12.2°, diagonal FOV 70° to 26.8°
Focus	Manual, (AF) Model: Auto
Aperture	F1.6-C/F1.6-25/F1.6
Illuminator	
Built-in Supplement Light Type	IR light
Light Bead	3
Built-in Supplement Light Range	Up to 30 m
IR Wavelength	850 nm
External Supplement Light	Strobe and flash light
Video	
Main Stream	50 Hz: 50 fps (4096 × 2160, 3840 × 2160, 3392 × 2008, 3072 × 1728, 2688 × 1520, 1920 × 1200, 1920 × 1080, 1280 × 720) 60 Hz: 30 fps (4096 × 2160, 3840 × 2160, 3392 × 2008, 3072 × 1728, 2688 × 1520, 1920 × 1200, 1920 × 1080, 1280 × 720)
Sub-Stream	50 Hz: 50 fps (3392 × 2008, 2688 × 1520, 1920 × 1080, 1280 × 720, 704 × 576) 60 Hz: 30 fps (3392 × 2008, 2688 × 1520, 1920 × 1080, 1280 × 720, 704 × 576)
Third Stream	50 Hz: 50 fps (1920 × 1080, 1280 × 720, 704 × 576) 60 Hz: 30 fps (1920 × 1080, 1280 × 720, 704 × 576)
Video Compression	Main stream: H.265/H.264/MJPEG, Sub-stream: H.265/H.264/MJPEG, Third stream: H.265/H.264/MJPEG
Video Bit Rate	32 Kbps to 16 Mbps
H.264 Type	Baseline profile/Main profile/High profile
H.265 Type	Main Profile
Network	
Protocols	TCP/IP, ICMP, HTTP, HTTPS, FTP, DNS, RTP, RTSP, RTCP, NTP, SNMP, 802.1X, IPv4/IPv6, UDP, ISUP, ARP, IGMP
Simultaneous Live View	Up to 6 channels
API	ONVIF (PROFILE S, PROFILE G, PROFILE T), ISAPI, SDK, ISUP
User/Host	Up to 32 users 3 user levels: administrator, operator and user

Security	Password protection, complicated password, HTTPS encryption, control timeout settings, 802.1X authentication (EAP-PEAP, EAP-LEAP, EAP-MD5), basic and digest authentication for HTTP/HTTPS, WSSE and digest authentication for Open Network Video Interface
Network Storage	Micro SD/TF card (512 GB), local storage, CVR, NVR, ANR
Client	iVMS-4200 (Only for live view and LPR information search), Hik-Central Master, Hik-Central Pro, HikCentral Master Lite
Web Browser	Chrome V61+, IE9 to IE11, Firefox V41+, Edge
Image	
Image Settings	Saturation, brightness, contrast, sharpness, AGC, and white balance are adjustable by client software or web browser.
Day/Night Switch	Auto, Schedule, Manual
SNR	60 dB
Image Enhancement	BLC, HLC, 3D DNR
Interface	
Ethernet Interface	2 RJ-45 10 M/100 M/1000 M self-adaptive Ethernet port(s)
On-Board Storage	Built-in memory card slot, supporting microSD/SDHC/SDXC card card, up to 512 GB
Alarm	2 input interfaces (T1, SYNC), 7 output interfaces
RS-485	3 RS-485 interfaces (half duplex, HIKVISION)
RS-232	1 RS-232 interface
USB	1 USB 2.0 interface
Event	
Basic Event	HDD Error, network disconnected, IP address conflicted, vehicle detector exception, traffic light detector exception
Road Traffic and Vehicle Detection	
Coverage	Up to 3 lane(s)
Trigger Mode	External I/O trigger/Radar trigger/Video trigger
Smart Function	License plate recognition, vehicle type classification, vehicle color recognition, no-plate vehicle capture, moving direction detection

LPR Countries/Regions	<p>Middle East: The United Arab Emirates (Abu Dhabi, Ajman, Dubai, Fujairah, Ras Al Khaimah, Sharjah and Umm Al Quwain), Qatar, Iraq, Egypt, Jordan, Kuwait, Saudi Arabia, Pakistan, Oman, Lebanon, Bahrain</p> <p>Africa: Nigeria, Kenya, Ivory Coast, South Africa, Tanzania, Mauritius, Morocco, Tunisia, Sierra Leone, Zambia, Ghana, Zimbabwe, Uganda, Angola, Ethiopia, Senegal, Algeria</p> <p>Asia-Pacific: Australia, New Zealand, Indonesia, Malaysia, Singapore, South Korea, Thailand, Vietnam, the Philippines, Hong Kong, Macao, Taiwan, Myanmar, India, Mongolia, Cambodia, Laos, Bangladesh, Nepal, Sri Lanka</p> <p>America: Canada, Argentina, Chile, Paraguay, Uruguay, El Salvador, Bolivia, Colombia, Brazil, Ecuador, Peru, Mexico, Panama, Costa Rica, Trinidad and Tobago, the Dominican Republic, Guatemala</p> <p>Europe: Turkey, Croatia, Slovakia, Czech Republic, Bulgaria, the Republic of North Macedonia, Hungary, Greece, Poland, France, Netherlands, Switzerland, Spain, the UK, Ireland, Germany, Italy, Austria, Israel, Palestinian, Belgium, Luxembourg, Albania, Kosovo, Serbia, Romania, Montenegro, Denmark, Finland, Sweden, Slovenia, Portugal, Malta, Cyprus, Iceland, Liechtenstein, Bosnia and Herzegovina</p> <p>Russian-Speaking Regions: Azerbaijan, Belarus, Kazakhstan, Lithuania, Georgia, Estonia, Latvia, Russia, Ukraine, Moldova, Uzbekistan, Kyrgyzstan, Armenia, Turkmenistan, Tajikistan</p>
Accuracy (Under recommended installation and lighting conditions)	<p>Capture rate > 99%,</p> <p>Vehicle moving direction recognition accuracy > 98.5%,</p> <p>LPR accuracy > 98%,</p> <p>Mistaken capture rate < 2%</p>
No License Plate Detection	Supported
Motorcycle LPR	Supported
Vehicle Type	Car, Van, Bus, Truck, Light Truck, SUV(MPV), Pickup, Motorcycle, Tricycle
Vehicle Color	Red, yellow, green, blue, pink, purple, cyan, brown, white, grey, black Recognizable at daytime only.
Vehicle Manufacturer	84 manufacturers: Hyundai, Toyota, KIA, Honda, Volkswagen, Benz, Nissan, Ford, Isuzu, BMW, Chevrolet, Mitsubishi, Renault, Opel, Suzuki, Skoda, Daewoo, Audi, Mazda, GAC HINO, Peugeot, SsangYong, Citroen, Fiat, Scania, MAN, Volvo, Lexus, Seat, Land Rover, Daihatsu, Dongwo, Subaru, Iveco, MINI, JEEP, Porsche, Chery, Dodge, Chrysler, Acura, Alfa Romeo, Great Wall, Infiniti, Smart, Saic Maxus, JAC, Jaguar, GMC, Lincoln, JMC, SAAB, FAW, Yutong, Guangzhou Yunbao, Joylong, Geely, Cadillac, JBC, An'kai, Haima, Foton, King Long, Dongfeng, Geely-Emgrand, Perodua, UD, BYD, Renault Samsung, Proton, HICOM, Malaysia_Unknown 1, Hyundai-Rohens, SsangYong-Old Version, Equus-Old Version, CNHTC, Rolls-Royce, Beiben Truck, Haval, Hino, Kia-Borrego, Chang'an, Alfa, FORO
License Plate Color Recognition	Customized to support
Driving on Lane Line Detection	Supported (only strobe light mode)
Lane Change Detection	Supported (only strobe light mode)
Wrong-Way Driving Detection	Supported
Emergency Lane Occupation	Supported (truck forbidden lane, emergency lane, urban bus lane)
Seatbelt Detection	Supported (with flash supplement light)
Phone Call Detection	Supported (with flash supplement light)
Capture Speed Range	10 to 320 km/h

General	
Operating System	Linux
Power	AC 100 V to 240 V, 1.5 A, max. 35 W, 3-core terminal block
Material	Aluminum alloy
Dimension	501.0 mm × 175.6 mm × 144.6 mm (19.72" × 6.92" × 5.69") (L × W × H)
Package Dimension	667 mm × 357 mm × 224 mm (26.26" × 14.06" × 8.82") (L × W × H)
Weight	Approx. 5.13 kg (11.31 lb.)
With Package Weight	Approx. 7.4 kg (16.31 lb.)
Operating Condition	-30 °C to 70 °C (-22 °F to 158°F). Humidity: 5% to 95% (non-condensing)
Storage Condition	-30 °C to 60 °C (-22 °F to 140 °F). Humidity 95% or less (non-condensing)
General Function	Password protection, three streams, heartbeat, one-key reset, pixel counter
Heater	Supported
Language	8 languages: English, Russian, Croatian, Korean, Russian, Traditional Chinese, Ukrainian, Spanish
Approval	
EMC	CE-EMC: EN 55032: 2015/A11:2020+A1: 2020, EN IEC61000-3-2: 2019/A1:2021, EN 61000-3-3: 2013+A1:2019/A2: 2021, EN 50130-4: 2011 +A1: 2014
Safety	CE-LVD: EN 62368-1: 2014/A11: 2017,CB: IEC 62368-1: 2014+A11, CB: IEC 62368-1: 2018+A11
Environment	CE-RoHS: 2011/65/EU, WEEE: 2012/19/EU, Reach: Regulation (EC) No 1907/2006
Protection	IK10: IEC 62262:2002, IP67: IEC 60529-2013

▪ Typical Application

Hikvision products are classified into three levels according to their anti-corrosion performance. Refer to the following description to choose for your using environment.

This model has NO SPECIFIC PROTECTION.

Level	Description
Top-level protection	Hikvision products at this level are equipped for use in areas where professional anti-corrosion protection is a must. Typical application scenarios include coastlines, docks, chemical plants, and more.
Moderate protection	Hikvision products at this level are equipped for use in areas with moderate anti-corrosion demands. Typical application scenarios include coastal areas about 2 kilometers (1.24 miles) away from coastlines, as well as areas affected by acid rain.
No specific protection	Hikvision products at this level are equipped for use in areas where no specific anti-corrosion protection is needed.

▪ Available Model

iDS-TCV900-BI(F)/25/H1(24V)

iDS-TCV900-BI(F)/25/H1

iDS-TCV900-BI(F)/1140/H1

iDS-TCV900-BI(F)/1140/H1(AF)

▪ Dimension

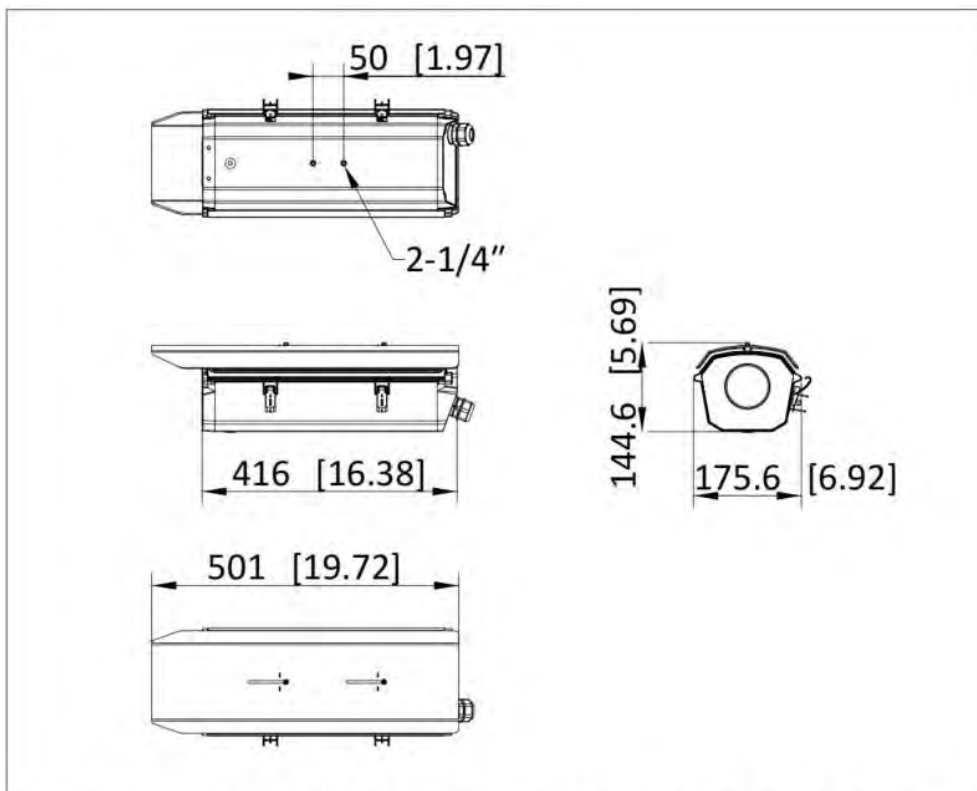

L× W× H:501mm× 175.6mm× 144.6mm(19.72× 6.92× 5.69)

Camera Mounting Hole[mm]	Camera Mounting Hole[inch]	Unit: mm [inch]	
2-6.35	2-1/4"	SCALE	1:1



▪ **Accessory**

▪ **Included**

DS-1232ZJ-T/BJH
Cardan Joint



▪ **Optional**

DS-1278ZJ-HWB Hoop & Bracket	DS-1275ZJ/HKB Hoop & Bracket	DS-1701ZJ/HKB Hoop & Bracket
		

Headquarters

No.555 Qianmo Road, Binjiang District,
Hangzhou 310051, China
T +86-571-8807-5998
www.hikvision.com



Follow us on social media to get the latest product and solution information.

